

**PT280-24 Series
Light Duty Pan/Tilt**

**Installation/
Operation Manual**

C324M-I (8/98)

CONTENTS

Section	Page
1.0 GENERAL	5
1.1 IMPORTANT SAFEGUARDS AND WARNINGS	5
2.0 DESCRIPTION	6
2.1 MODELS	6
2.2 CERTIFICATIONS	6
3.0 INSTALLATION	7
3.1 MOUNTING	7
3.2 CAMERA/ENCLOSURE INSTALLATION	7
3.3 ELECTRICAL INSTALLATION	7
3.3.1 Mating Connector Assembly	9
3.4 LIMIT STOP ADJUSTMENTS	13
4.0 OPERATION	14
5.0 TROUBLESHOOTING	15
5.1 SERVICE MANUAL	15
6.0 MAINTENANCE	16
6.1 TIGHTENING DRIVE CHAINS	16
6.2 CHAIN DRIVE LUBRICATION	16
7.0 SPECIFICATIONS	17
8.0 WARRANTY AND RETURN INFORMATION	20

LIST OF ILLUSTRATIONS

Figure	Page
1 Connector Assembly	9
2 PT280-24P/PT280-24SL Wiring Diagram	10
3 PT280-24P/PP Wiring Diagram	11
4 PT280-24SL/PP Wiring Diagram	12
5 Limit Stops	13
6 Servicing the Pan and Tilt	16
7 PT280-24 Series Dimension Drawings	19

LIST OF TABLES

Table	Page
A Requirements to Wire 24 VAC Power to Pan and Tilt Motors	8

REVISION HISTORY

Manual #	Date	Comments
C324M	12/89	Original manual.
C324M	4/90	Revision A. Manual updated with improved wiring diagrams.
C324M	7/90	Revision B. Manual revised with updated wiring diagram and corrected mechanical parts list.
C324M	2/91	Revision C. Manual revised to include updated wiring diagram.
C324M	4/92	Revision D. Manual revised to include updated manual format and corrected wiring diagram.
C324M	10/92	Revision E. Manual revised to include updated wiring diagram.
C324M-F	2/95	Revision F. Manual revised to include changes to exploded assembly diagram, materials list and wiring diagrams.
C324M-G	6/95	Revision G. Manual revised to include exploded assembly diagram (parts) and respective materials list.
C324M-H	10/96	Revised installation instructions. Added Table A. Updated Table C and Specifications.
	10/97	Figures 4 and 5 revised to show correct wire colors for pins 5 and 6. Figure 3 revised to show correct pin outs on lens connector.
C324M-I	8/98	Changed manual to new format. Added certifications. Revised installation instructions. Moved exploded assembly diagrams and parts lists to maintenance/service manual. Added maintenance instructions. Changed tilt torque specification from 5 inches to 2 inches.

(This page intentionally left blank)

1.0 GENERAL

1.1 IMPORTANT SAFEGUARDS AND WARNINGS

Prior to installation and use of this product, the following WARNINGS should be observed.

1. Installation and servicing should only be done by qualified service personnel and conform to all local codes.
2. Unless the unit is specifically marked as a NEMA Type 3, 3R, 3S, 4, 4X, 6, or 6P enclosure, it is designed for indoor use only and it must not be installed where exposed to rain and moisture.
3. The weight of the camera, lens, and enclosure shall not exceed 15 lb (6.81 kg).
4. Only use replacement parts recommended by Pelco.
5. After replacement/repair of this unit's electrical components, conduct a resistance measurement between line and exposed parts to verify the exposed parts have not been connected to line circuitry.
6. The installation method and materials should be capable of supporting four times the weight of the enclosure, pan/tilt, camera and lens combination.

The product and/or manual may bear the following marks:



This symbol indicates that dangerous voltage constituting a risk of electric shock is present within this unit.



This symbol indicates that there are important operating and maintenance instructions in the literature accompanying this unit.

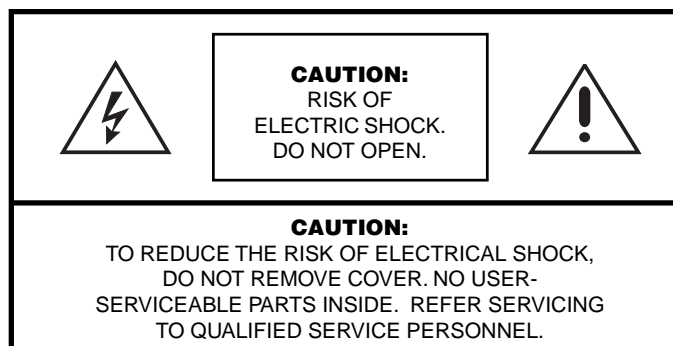

**Please thoroughly familiarize yourself with the information
in this manual prior to installation and operation.**

2.0 DESCRIPTION

The pan/tilts of the PT280-24 Series are mini-size, light duty, indoor units capable of supporting loads up to 15 pounds (6.8 kg). They operate on 24 VAC.

They are factory pre-wired for pan and tilt control functions, motorized zoom lens operation, camera power, and video. All connections are made at the input/output connectors, eliminating the need for wiring harnesses. This greatly reduces installation time, while increasing reliability and serviceability.

Pan/tilts in the PT280-24 Series are ideally suited for use with discreet surveillance enclosures.

2.1 MODELS

PT280-24P	Mini-size, light duty pan/tilt, 24 VAC
PT280-24SL	Mini-size, light duty pan/tilt with 360° pan rotation, 24 VAC
PT280-24P/PP	Same as PT280-24P except with preset positioning capabilities.
PT280-24SL/PP	Same as PT280-24SL except with preset positioning capabilities.

2.2 CERTIFICATIONS

The products identified below have been tested and certified for agency compliance as noted.

Model	Agency Compliance Certification			
	CE	FCC	UL	CSA/cUL
PT280-24P	X		X	
PT280-24P/PP	X		X	
PT280-24SL	X		X	
PT280-24SL/PP	X		X	

Applicable CE, FCC, UL, and CSA/cUL standards:

- CE Class B
- UL Standard 2044

Additional applicable ratings:

- NEMA Type 1
- IP 20

3.0 INSTALLATION

To ensure proper wiring and operation of your equipment, it is recommended that you test the pan/tilt and associated equipment in your facility before installing it in the field. Refer to Sections 3.2 through 3.4.

3.1 MOUNTING



CAUTION: *Pan/tilts in the PT280-24 Series are for indoor use. Do not install outdoors. They are designed to operate in an upright or inverted position only. Do not mount the pan/tilts horizontally.*

The pan/tilt unit can be mounted upright or inverted. Attach it to a flat surface. If you use a wall, ceiling, or pedestal mount, follow the instructions that are provided with the mount. Make sure the mounting surface can support four times the combined weight of the pan/tilt, enclosure, camera and lens. The PT280-24P and PT280-24P/PP models weigh 9 pounds (4.05 kg). The PT280-24SL and PT280-24SL/PP models weigh 11 pounds (4.95 kg). Refer to the manuals for your enclosure, camera, and lens for the weights of those units. The weight of the enclosure, camera and lens must not exceed 15 pounds (6.81 kg).

Proceed to Section 3.2, CAMERA/ENCLOSURE INSTALLATION.

3.2 CAMERA/ENCLOSURE INSTALLATION

Attach the enclosure, camera and lens to the pan/tilt unit with 1/4-20 hardware (not supplied).

Proceed to Section 3.3, ELECTRICAL INSTALLATION.

3.3 ELECTRICAL INSTALLATION

1. Assemble and connect the cable between the pan/tilt and controller.

On the pan/tilt, the cable connects to either the 14-pin or 28-pin connector. The mating connector is supplied with the pan/tilt as loose equipment. To assemble the 14-pin or 28-pin connector to the cable, refer to Section 3.3.1, Mating Connector Assembly.

The pan and tilt motors require 24 VAC. Refer to Table A to determine the size of wire to use. An RB24 Relay Box can be used to extend the distance between the pan/tilt and controller.

To assemble the other end of the cable, refer to the documentation for the equipment to which it will connect.

2. Make the cable for the camera lens functions and connect it to the pan/tilt and camera. On the side of the pan/tilt is either a 6-pin or 9-pin connector that is for camera lens functions. The mating connector is supplied with the pan/tilt as loose equipment. To assemble the 9-pin connector to the cable, refer to Section 3.3.1, Mating Connector Assembly. Refer to Figure 2 to wire the 6-pin connector.

To assemble the other end of the cable, refer to the documentation for the camera.

3. Connect the BNC connector from the pan/tilt to the video output of the camera.
4. Connect the black wires with the spade lugs from the pan/tilt to the power input on the camera. The other ends of the wires go to pins 9 and 14 of the 14- or 28-pin connector as shown in the wiring diagrams in Figures 2-4. Connect the spade lugs to match the wiring of pins 9 and 14. Use an ohmmeter or continuity checker to determine which spade lug goes to which pin.

Proceed to Section 3.4, LIMIT STOP ADJUSTMENTS.

Table A. Requirements to Wire 24 VAC Power to Pan and Tilt Motors

Model	Wire Size (AWG)	Maximum Distance "A" (5 Conductors*)	Maximum Distance "B" (5 Conductors*)	Maximum Distance "B" (6 Conductors**)
All models	20	5,800 ft (1,768 m) ***	110 ft (33.53 m)	210 ft (64.01 m)
	18	8,250 ft (2,515 m)	180 ft (54.86 m)	330 ft (100.58 m)
	16	13,000 ft (3,962 m)	290 ft (88.39 m)	530 ft (161.54 m)

IMPORTANT NOTE: If RB24 Relay Box is not used, maximum cable length is distance "B."
 * Conductors are for up, down, left, and right functions, plus motor common. Cable distances are calculated with both motors (pan and tilt) running and assuming a 10% voltage drop in the cable.
 ** Same as five conductors except two wires are used for motor common.
 *** Not recommended for reliable service between control and relay box.

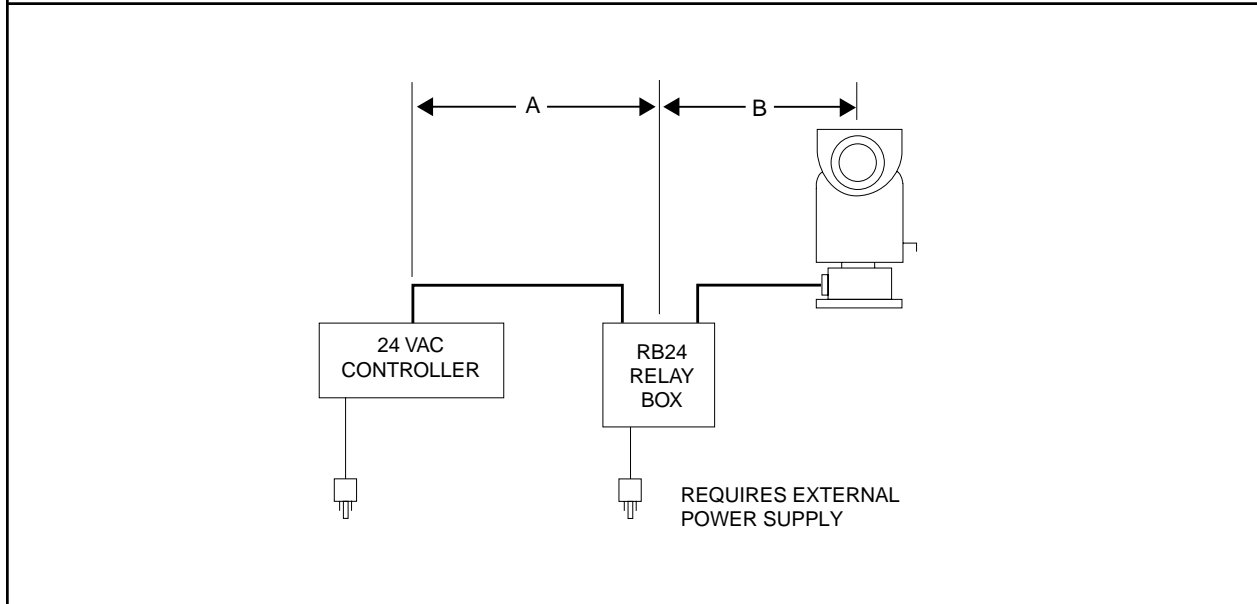

3.3.1 Mating Connector Assembly

NOTE: Contacts cannot be removed from the connector without the use of the appropriate AMP extraction tool (ZT305183 for 9-pin and 14-pin connectors and ZT91067-2 for 28-pin connectors), which is available from Pelco.

NOTE: When a pan/tilt is mounted in the inverted position, the LEFT/RIGHT and UP/DOWN functions are reversed during operation. To correct this problem, reverse the LEFT/RIGHT functions in the control cable (pins 3 and 7) at the pan/tilt or control and the UP/DOWN functions (pins 5 and 6) at the pan/tilt or control.

To assemble the mating connectors, refer to Figure 1 and perform the following steps.

The instructions that follow apply to all AMP style connectors regardless of pin size or pin number.

1. Slide the connector clamp assembly over the conductor cable. If the diameter of the conductor cable is such that the rubber boot will slide over it easily, slide the rubber boot onto the conductor cable at this time. If not, discard the rubber boot.
2. Refer to Detail A in Figure 1. Prepare the wires from the conductor cable as follows:
 - a. Strip at least 1-inch (2.54 cm) from the cable jacket to expose the wires. You may need to strip more from the cable jacket if you have more wires.
 - b. Strip 1/8-inch (0.125 cm) from each wire.
 - c. Using an AMP style crimper, crimp the wires and their insulation to the connector pins.
3. Slide the connector pins into the appropriate holes in the connector body until they snap into place. Refer to detail B in Figure 1 and to Figures 2-4 for correct pin arrangement, depending on model and options.
4. Push the connector clamp assembly (with boot, if used) toward the connector body. Screw the clamp assembly onto the connector body, being careful not to disturb the wires.
5. To complete the assembly, attach the appropriate clamp with the screws provided and tighten.

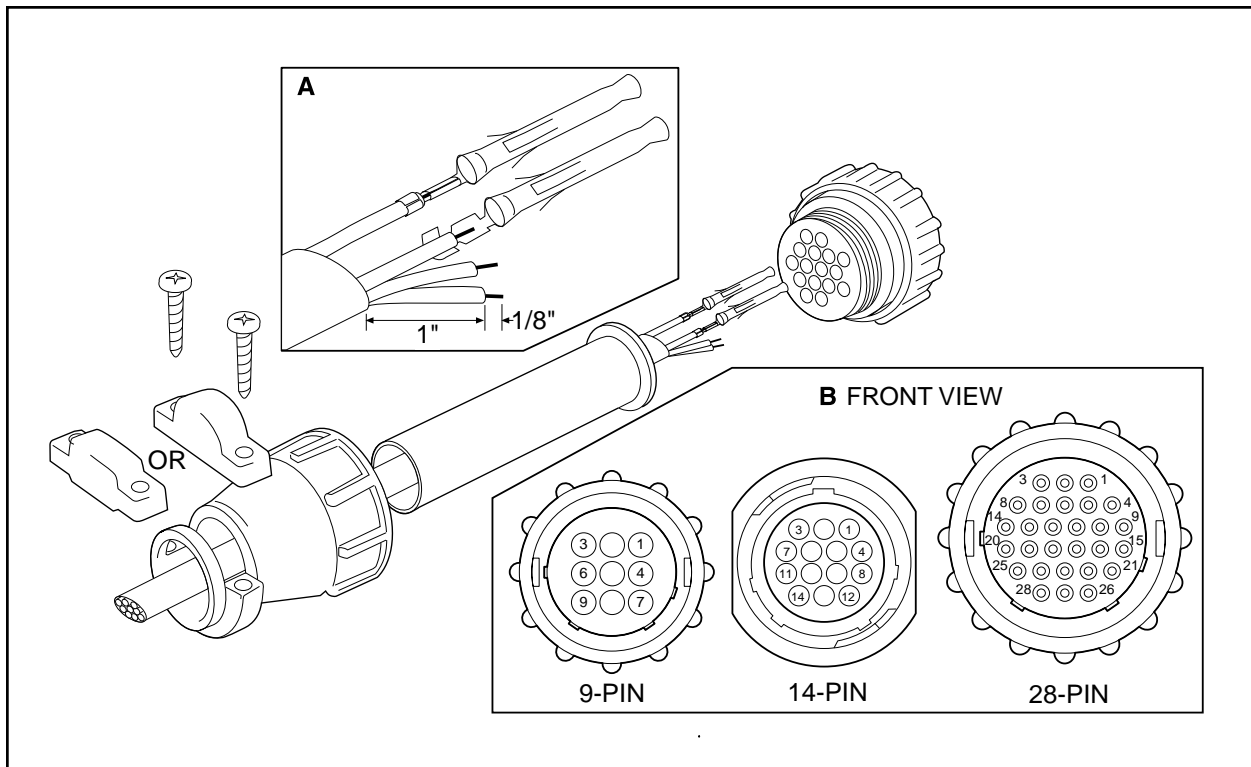

Figure 1. Connector Assembly

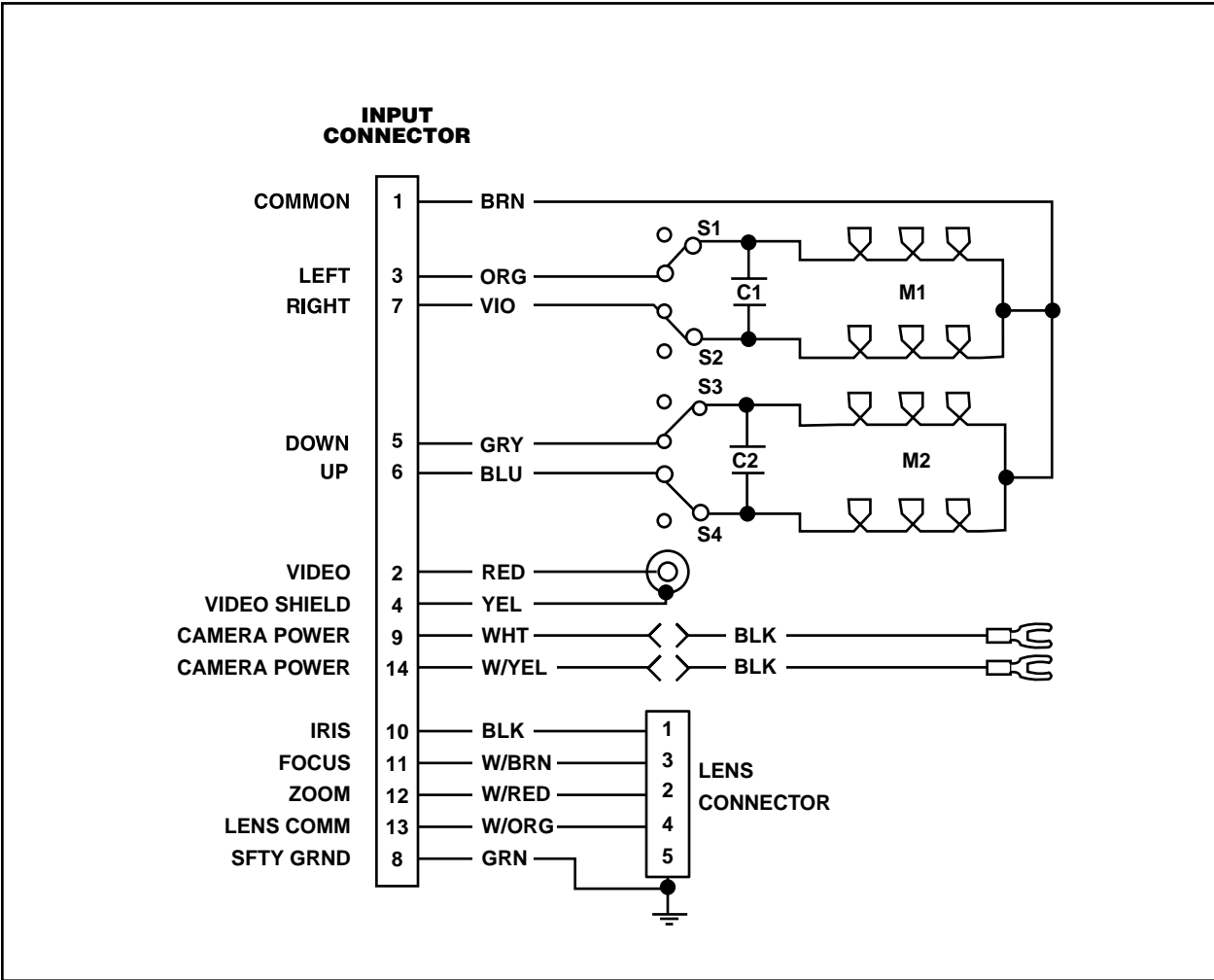

Figure 2. PT280-24P/PT280-24SL Wiring Diagram

28-PIN PAN/TILT SPINDLE CONNECTOR

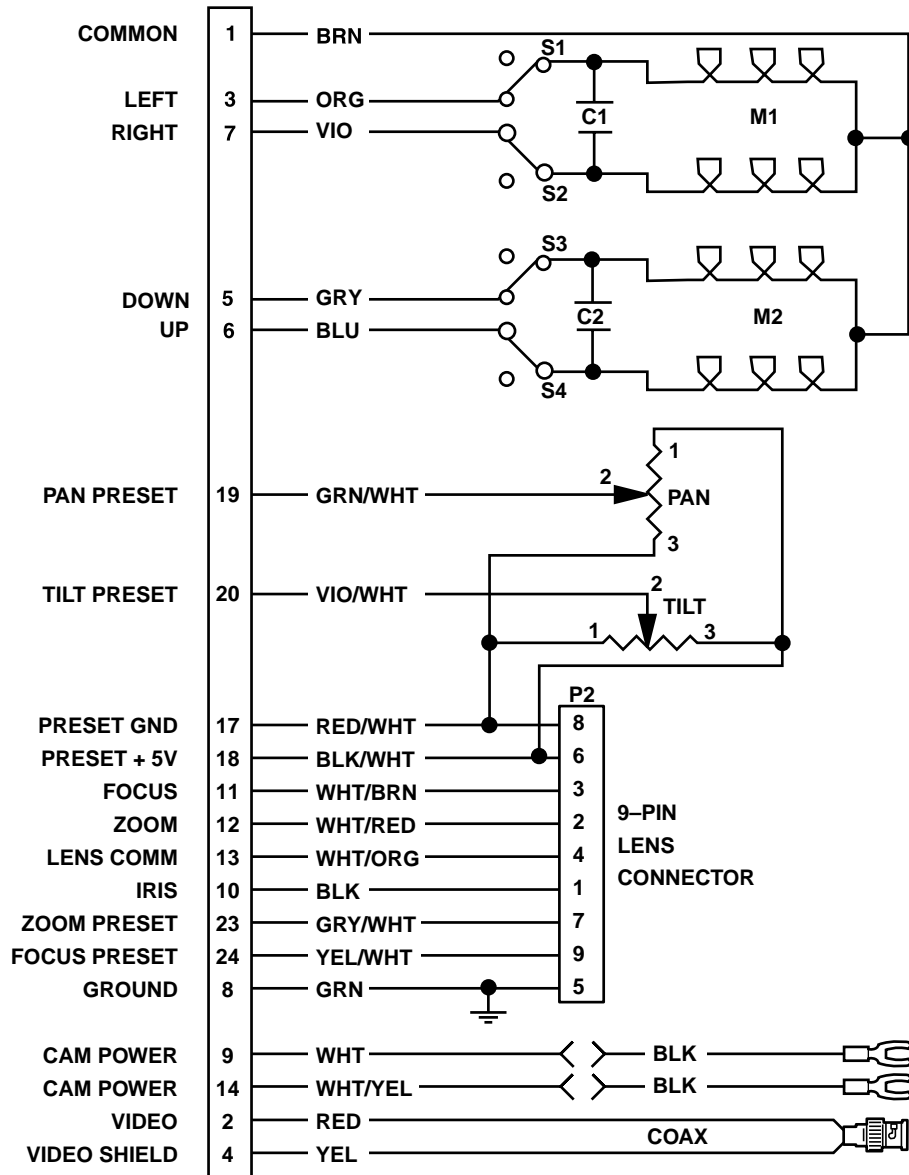

Figure 3. PT280-24P/PP Wiring Diagram

28-PIN PAN/TILT SPINDLE CONNECTOR

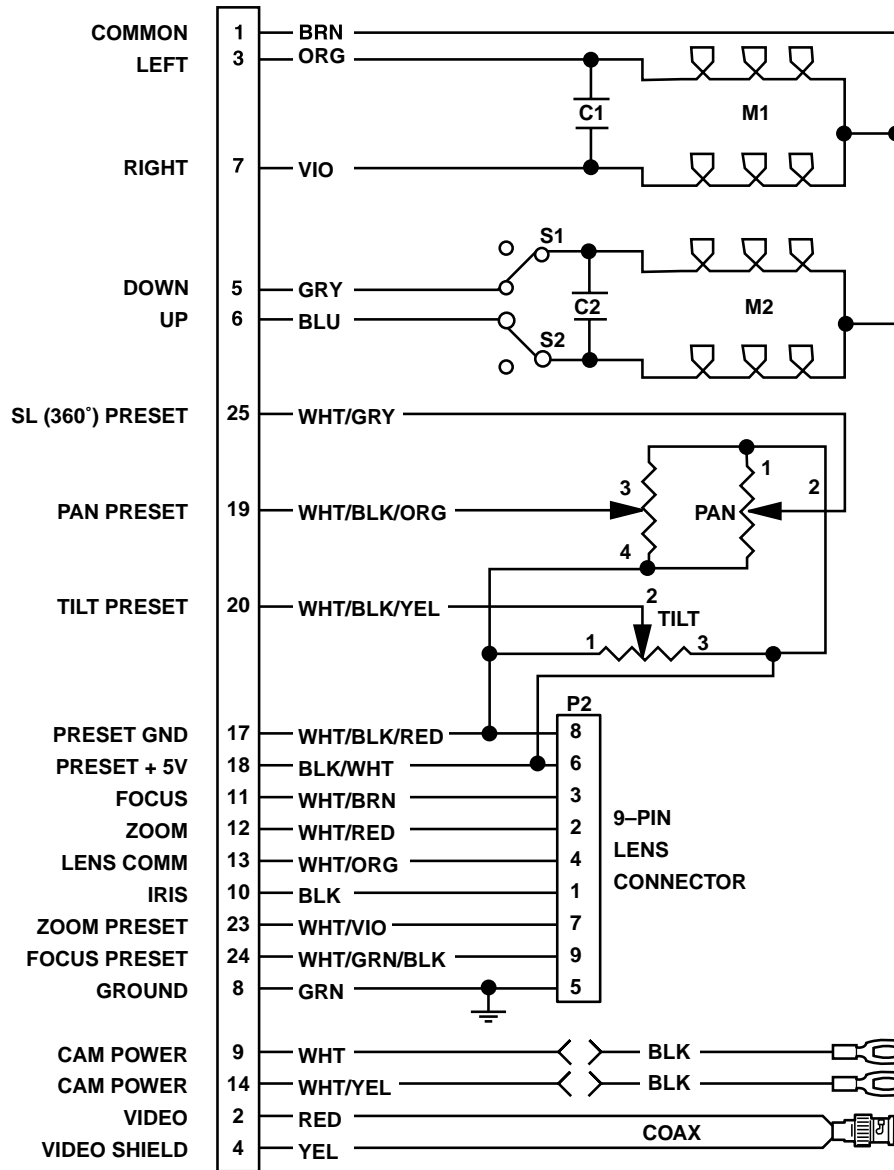

Figure 4. PT280-24SL/PP Wiring Diagram

3.4 LIMIT STOP ADJUSTMENTS



WARNING: Do not operate pan/tilt without limit stops. Do not attempt to adjust the limit stops while the unit is operating. Personal injury or damage to the unit may result.

Do not remove or reposition the fixed limit stop on the pan/tilt. DAMAGE WILL OCCUR.

NOTE: The PT280-24SL and PT280-24SL/PP do not have pan limit stops. Disregard steps 1-5.

To set pan/tilt limit stops, perform the following steps. Refer to Figure 5.

1. Loosen the pan limit stops.
2. Turn on the control unit. Pan the unit to the right until the desired right pan limit is reached.
3. Move the right pan limit stop until it touches the pan limit switch actuator. Push the stop against the actuator until it clicks, indicating that the limit switch has opened. Lock the stop in place.
4. Pan the unit to the desired left position. Adjust the left pan limit stop as described in step 3.
5. Pan left and right to both limit stops and check for exact positioning. Tighten both stops securely.
6. Remove the cover plate from the left side of the tilt table. Turn on the control unit if you are starting at this step. Loosen the limit stop screws and tilt the table to the desired up position.
7. Move the up limit stop until it touches the tilt limit switch actuator. Push the stop against the actuator until it clicks, indicating that the limit switch has opened. Lock the stop in place.
8. Tilt the table to the desired down position and set the stop as described in step 7.
9. Tilt the table up and down and check for exact positioning. Tighten both stops securely. Replace the cover plate.

NOTE: COVER PLATE NOT SHOWN IN THIS ILLUSTRATION.

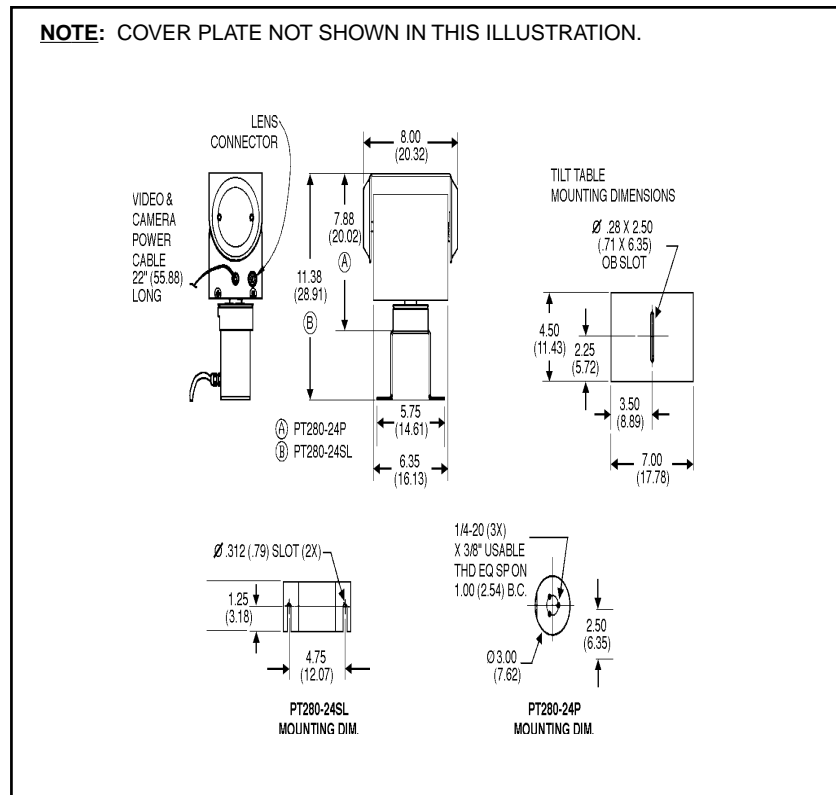

Figure 5. Limit Stops

4.0 OPERATION

Refer to the manual for your control equipment for operating the pan/tilt unit.

The pan/tilts of the PT280-24 Series will function in the Auto/Random mode when used with the appropriate Pelco control system. The pan/tilt has no additional limit switches or relays for auto scan operation and is, therefore, only compatible with current sensing auto/random type circuits used in the controller.

5.0 TROUBLESHOOTING

Some common problems encountered with pan/tilt systems include miswiring, overloading, and not using the units for the correct application. If the pan/tilt unit fails to operate, do the following:

1. Check the fuse in the control unit. If the fuse is bad, replace it.
2. If the fuse blows after replacing it, check the control cable between the control unit and the pan/tilt for shorts, high resistance, or opens.
3. If the control cable is good, reconnect it to the control unit but not to the pan/tilt. Replace the fuse and operate the control unit. If the fuse blows again, the fault is in the control.

Refer to Figures 2-4 for the following steps.

4. If the control unit is good, check the wiring harness in the pan/tilt for shorts.
5. If the wiring harness is good, check the motor starting capacitors.
6. If the starting capacitors are good, check the motors for opens and shorts. There should be low resistance between the windings.
7. Check the limit switches for opens and shorts.

5.1 SERVICE MANUAL

If you need to service your unit, obtain a service manual in one of the following ways:

- Go to Pelco's web site at <http://www.pelco.com> and find service manual C323SM.
- Contact Pelco's Literature Department and request service manual C323SM.

6.0 MAINTENANCE

Inspect the pan/tilt unit every six months to ensure trouble-free operation and an extended product life. Harsh environments and/or continuous motion applications may require more frequent maintenance.

Please read all of the instructions that follow before servicing the pan/tilt.

To begin, remove the two screws on the back of the pan/tilt housing and lift the cover to gain access to the pan and tilt motor assemblies.

6.1 TIGHTENING DRIVE CHAINS

Check the pan and tilt drive chains for tension. A movement of 1/32 of an inch to 3/32 of an inch in the chains is acceptable. If the movement of a chain exceeds 3/32 of an inch, adjust the chain as follows:

1. Loosen the screws securing the motor to the mounting frame.
2. Pry on the motor to apply tension to the chain. Do not over-tension the drive chain.
3. Keep tension on the chain while tightening the screws.

6.2 CHAIN DRIVE LUBRICATION

Sprockets and chains should be well greased. If necessary, lubricate the pan and tilt sprockets and chains as follows with a high-quality grease capable of withstanding temperatures from -50° to 170°F (-46° to 77°C). Do the following:

1. Liberally apply grease to the pan and tilt drive chains and sprockets (refer to Figure 6).
2. Operate the pan and tilt motors to spread the grease across the parts.
3. Apply additional grease if necessary.
4. Reinstall the cover.

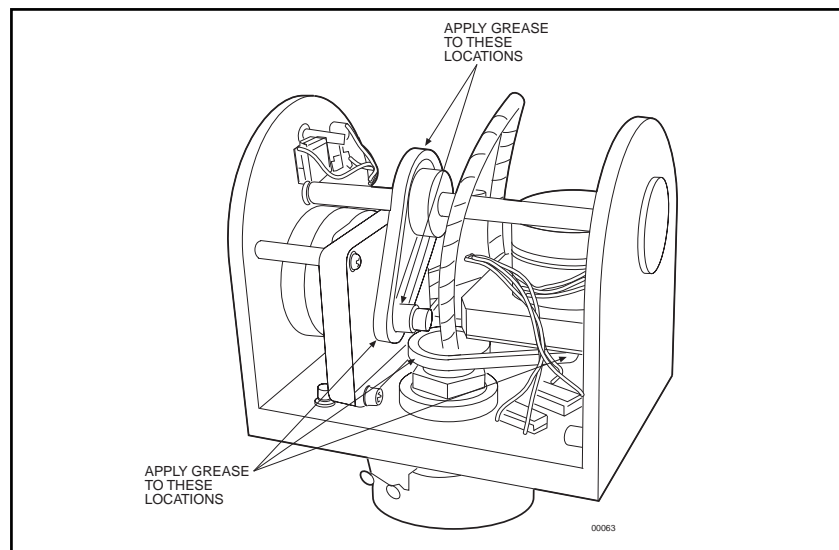

Figure 6. Servicing the Pan and Tilt

7.0 SPECIFICATIONS

MECHANICAL

Pan:	Movement in horizontal plane: PT280-24P 0-355° PT280-24P/PP 0-355° PT280-24SL 360° PT280-24SL/PP 360°
Pan Speed:	12°/sec ±1° (No load condition)
Tilt:	±90° movement in vertical plane
Tilt Speed:	3°/sec ±.5° (No load condition)
Maximum Load:	15 lb (6.8 kg) at 2 inches (5.08 cm) from tilt table surface to center of gravity (upright or inverted)
Gearing:	Chain and sprocket final drive
Bearings:	
Pan	Heavy duty ball bearings
Tilt	Oilite bronze bushing
Braking:	Friction

ELECTRICAL

Input Voltage:	24 VAC required for pan/tilt
Power Requirements:	Running
Pan	.31 amp (7.5 vA)
Tilt	.38 amp (9.2 vA)
	Starting
Pan	.47 amp (11.2 vA)
Tilt	.56 amp (13.5 vA)
Maximum Current:	2 amps per conductor (SL model only)
Connectors:	Amp CPC type, mate supplied, installed onto a pigtail exiting from the base of the unit (all functions: camera power, lens, pan/tilt and video)
Video Connector:	BNC
Camera Power:	Spade lugs
Motors:	Two-phase induction type, continuous duty, instantaneous reversing
Limit Switches:	
Pan	5 amp (external adjustment)
Tilt	5 amp (external adjustment)

GENERAL

Construction: Aluminum plate, all internal parts corrosion protected

Environment: Indoor

Temperature: 32° to 120°F (0°C to 49°C)

Dimensions: See Figure 7

Weight:

PT280-24P,
PT280-24P/PP 9 lb (4.05 kg)

PT280-24SL
PT280-24SL/PP 11 lb (4.95 kg)

Shipping Weight:

PT280-24P,
PT280-24P/PP 11 lb (4.95 kg)

PT280-24SL
PT280-24SL/PP 12 lb (5.44 kg)

(Design and product specifications subject to change without notice.)

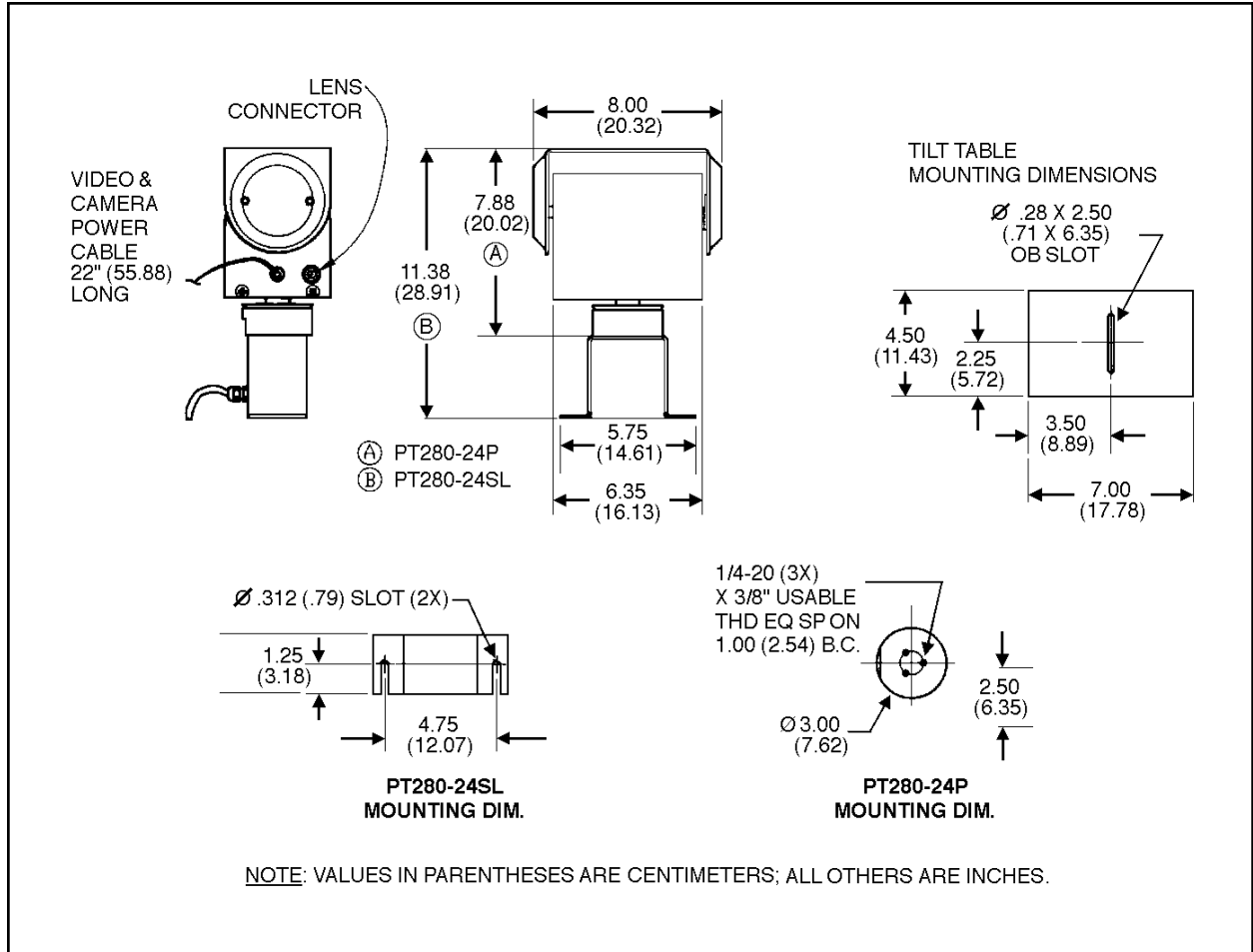

Figure 7. PT280-24 Series Dimension Drawings

8.0 WARRANTY AND RETURN INFORMATION

WARRANTY

Pelco will repair or replace, without charge, any merchandise proved defective in material or workmanship for a period of one year after the date of shipment.

Exceptions to this warranty are as noted below:

- Five years on FT/FR8000 Series fiber optic products.
- Three years on Genex® Series products (multiplexers, server, and keyboard).
- Three years on Camclosure® and fixed camera models, except the CC3701H-2, CC3701H-2X, CC3751H-2, CC3651H-2X, MC3651H-2, and CC3651H-2X camera models, which have a five-year warranty.
- Two years on standard motorized or fixed focal length lenses.
- Two years on Legacy®, CM6700/CM6800/CM9700 Series matrix, and DF5/DF8 Series fixed dome products.
- Two years on Spectra®, Esprit®, ExSite™, and PS20 Scanners, including when used in continuous motion applications.
- Two years on Esprit® and WW5700 Series window wiper (excluding wiper blades).
- Eighteen months on DX Series digital video recorders, NVR300 Series network video recorders, and Endura™ Series distributed network-based video products. months on DX Series digital video recorders, NVR300 Series network video recorders, Endura™ Series distributed network-based video products, and TW3000 Series twisted pair transmission products.
- One year (except video heads) on video cassette recorders (VCRs). Video heads will be covered for a period of six months.
- Six months on all pan and tilts, scanners or preset lenses used in continuous motion applications (that is, preset scan, tour and auto scan modes).

Pelco will warrant all replacement parts and repairs for 90 days from the date of Pelco shipment. All goods requiring warranty repair shall be sent freight prepaid to Pelco, Clovis, California. Repairs made necessary by reason of misuse, alteration, normal wear, or accident are not covered under this warranty.

Pelco assumes no risk and shall be subject to no liability for damages or loss resulting from the specific use or application made of the Products. Pelco's liability for any claim, whether based on breach of contract, negligence, infringement of any rights of any party or product liability, relating to the Products shall not exceed the price paid by the Dealer to Pelco for such Products. In no event will Pelco be liable for any special, incidental or consequential damages (including loss of use, loss of profit and claims of third parties) however caused, whether by the negligence of Pelco or otherwise.

The above warranty provides the Dealer with specific legal rights. The Dealer may also have additional rights, which are subject to variation from state to state.

If a warranty repair is required, the Dealer must contact Pelco at (800) 289-9100 or (559) 292-1981 to obtain a Repair Authorization number (RA), and provide the following information:

1. Model and serial number
2. Date of shipment, P.O. number, Sales Order number, or Pelco invoice number
3. Details of the defect or problem

If there is a dispute regarding the warranty of a product which does not fall under the warranty conditions stated above, please include a written explanation with the product when returned.

Method of return shipment shall be the same or equal to the method by which the item was received by Pelco.

RETURNS

In order to expedite parts returned to the factory for repair or credit, please call the factory at (800) 289-9100 or (559) 292-1981 to obtain an authorization number (CA number if returned for credit, and RA number if returned for repair).

All merchandise returned for credit may be subject to a 20% restocking and refurbishing charge.

Goods returned for repair or credit should be clearly identified with the assigned CA or RA number and freight should be prepaid. Ship to the appropriate address below.

If you are located within the continental U.S., Alaska, Hawaii or Puerto Rico, send goods to:

Service Department
Pelco
3500 Pelco Way
Clovis, CA 93612-5699

If you are located outside the continental U.S., Alaska, Hawaii or Puerto Rico and are instructed to return goods to the USA, you may do one of the following:

If the goods are to be sent by a COURIER SERVICE, send the goods to:

Pelco
3500 Pelco Way
Clovis, CA 93612-5699 USA

If the goods are to be sent by a FREIGHT FORWARDER, send the goods to:

Pelco c/o Expeditors
473 Eccles Avenue
South San Francisco, CA 94080 USA
Phone: 650-737-1700
Fax: 650-737-0933